

CDM833
WHEEL LOADER

- RATED POWER: 92kW/2200rpm
- BUCKET CAPACITY: 1.7 m³
- RATED PAYLOAD: 3000kg
- OPERATING WEIGHT: 10760kg

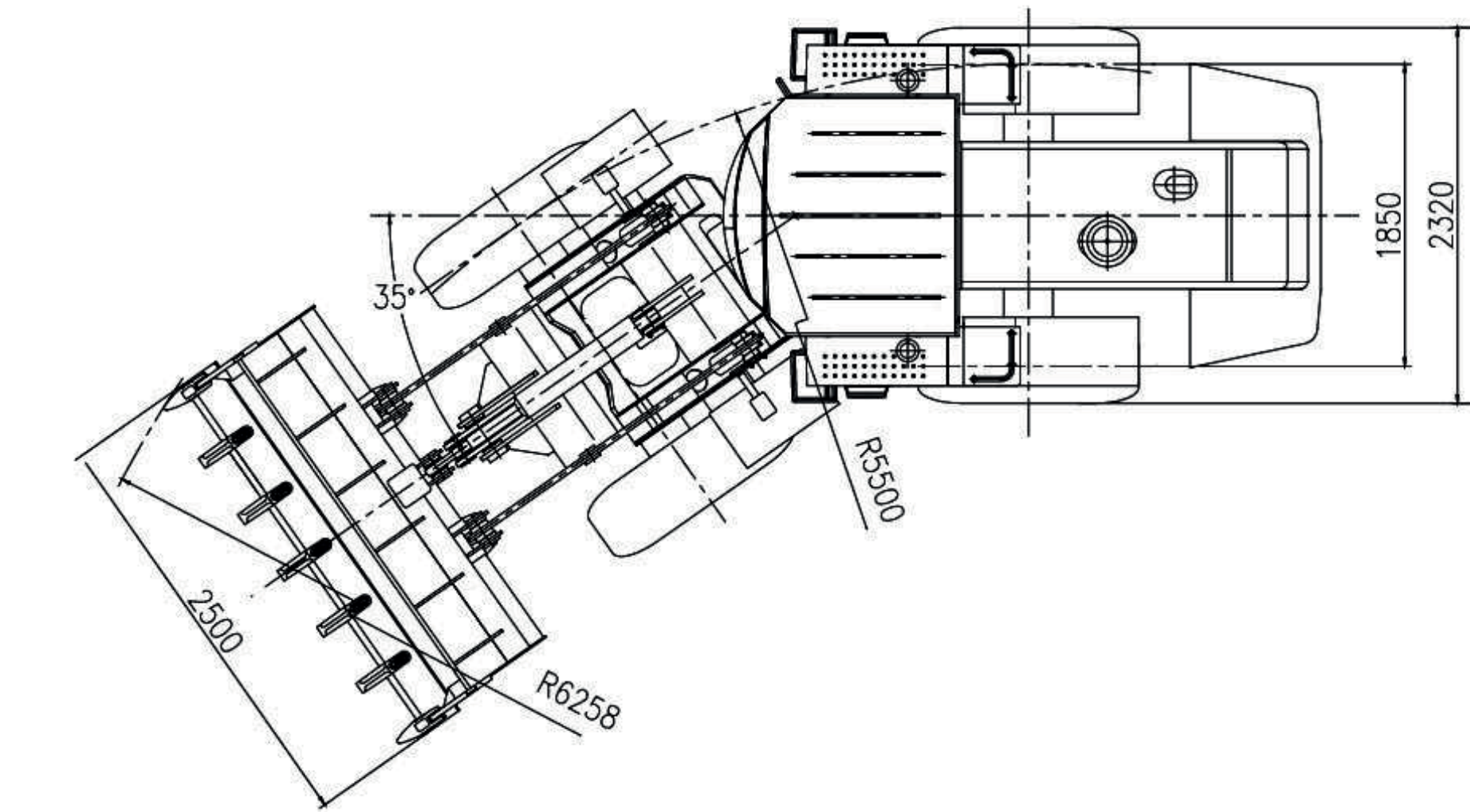
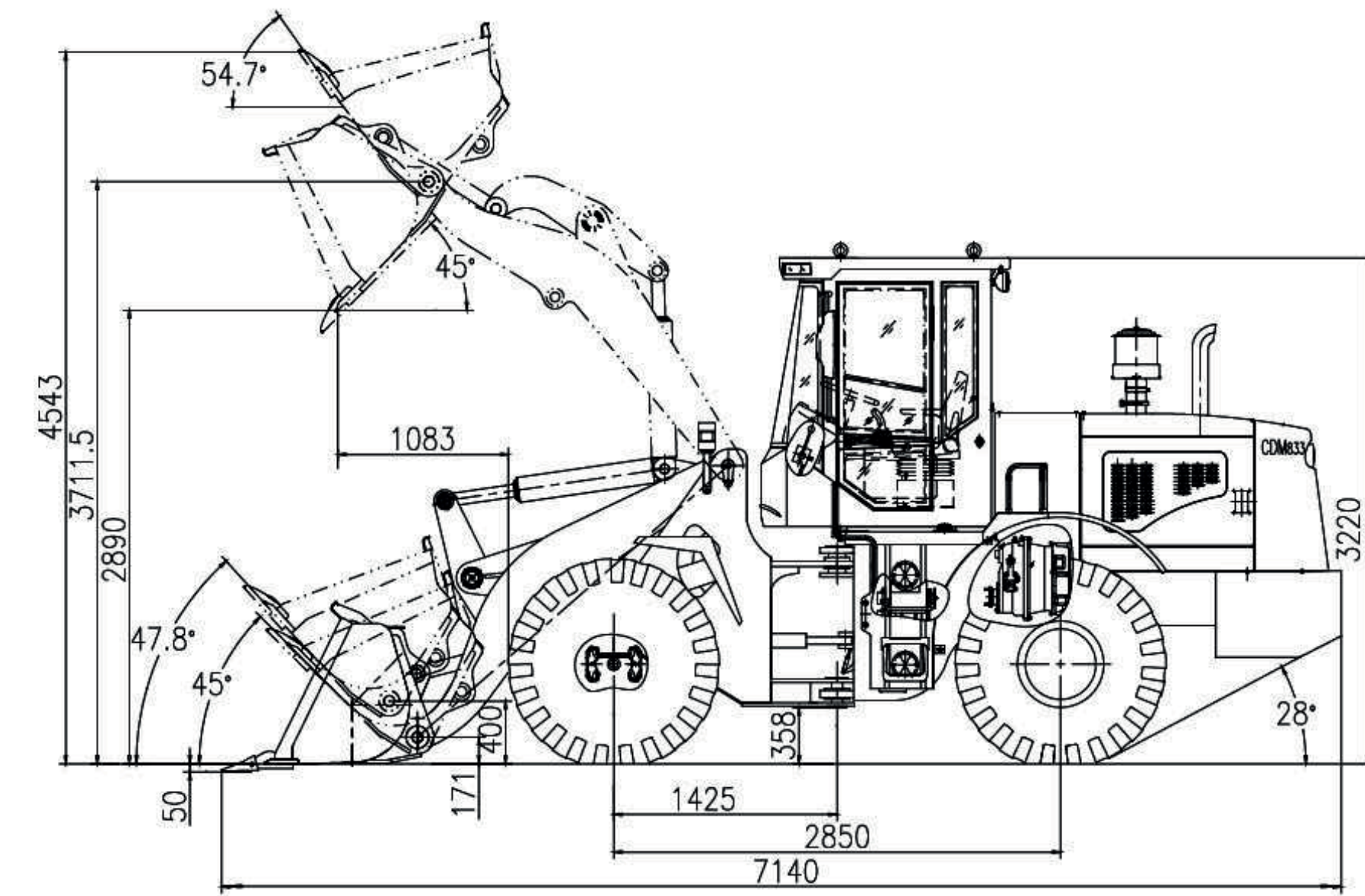

OVERALL DATA

Bucket Capacity (m ³)	1.7
Rated Payload(kg)	3000
Operating Weight(kg)	10760±300
Traction Force(kN)	97±3
Breakout Force(kN)	100±3
L×W×H(mm)	7140×2500×3220

Travel Speeds (km/h)	Travel Speeds (km/h)		
	I	II	III
Forward	6.5	12.0	32.0
Reverse	6.8	12.5	33.5

ENGINE WEICHAI WP6G125E22

Rated Power(kW·hp/rpm)	92·(125)/2200
Peak Torque(Nm/rpm)	500/1400-1600
Starting Voltage(V)	24

DRIVE TRAIN

Torque Converter	Single-stage, Single-turbine, 3-element
Torque Ratio	3.45
Transmission	Countershaft Powershift Transmission
Gear	3F/3R
Pressure of Transmission(MPa)	1.2~1.5
Main Reducer	Spiral bevel, 1-stage Reduction
Final Reducer	Planetary Reduction
Tire	17.5-25 L-3 12PR TT

BRAKE SYSTEM

Service Brake	Single Circuit Caliper, Dry Brake
Setting Pressure (MPa)	0.78
Parking Brake	Flexible Shaft Controlled Caliper
Emergency Brake	Flexible Shaft Controlled Caliper

STANDARD

WEICHAI Engine(Nation II)	Enlarged Fin-distance Radiator
Lonking Transmission	Coal Bucket (M) -2.5m ³
Lonking Axle	Enlarged Bucket (N) -2.3m ³
Mechanical Flexible Shaft Control	High Dumping(G)
Standard Bucket(1.7m ³)	Wood Fork(J)
Air Conditioner	Quick-Change 4 in 1 Bucket-1.5m ³

OPTIONAL

Fork	Quick Connector (H)
High Dumping Coal Bucket (T)-2.5m ³	Snow Blade
Radial Tire TT/TL	Pilot Control

STEERING SYSTEM

Type	Hydraulic Load Sensing System
Cylinders-bore×Stroke(mm)	2-80×315
Steering Pump	Gear Pump
System Pressure(MPa)	14
Flow Rate(L/min/rpm)	88/2200
Steering Angle	±35°

HYDRAULIC SYSTEM

Lift Cylinders-bore×Stroke(mm)	2-125×784		
Tilt Cylinder-bore×Stroke(mm)	1-140×553		
Model of Working Pump	Gear Pump		
Flow Rate(L/min/rpm)	176/2200		
System Pressure(MPa)	16		
Pilot Control System Pressure (MPa)	2.5		
Hydraulic Cycle Time, Rated Load in Bucket(In Second)			
Raise(Loaded)	Dump	Lower(Empty)	Total
5.5	1.3	3.7	10.5

ELECTRICAL SYSTEM

System Voltage(V)	24
Battery (2 in series)(Ah)	105
Lamp Voltage(V)	24

SERVICE REFILL CAPACITY

Fuel Tank(L)	200
Hydraulic Tank(L)	173
Crankshaft(L)	17
Transmission(L)	36
Front Axle(L) /Rear Axle(L)	18.5/18.5

AC SYSTEM

Heating Capacity(W)	5000 (±10%)
Cooling Capacity(W)	4200 (±10%)

Features:

- Weichai Deutz WP6G125E22 engine brings great power with low fuel-consumption.
- Lonking self-made radiator as standard with great radiating efficiency which has been tested by the practical condition, Enlarged fin-distance radiator as optional choice.
- CDM833 can select machinery flexible control or pilot control.
- New-type fuel tank with 200L capacity can increase the working time.
- CDM833 is standard equipped with detachable cab, Which is very convenient for container delivering.
- Efficient and healthy air conditioner.
- Enough space for operation and maintenance.
- Select many kinds of optional working devices.