

ZOOMLION

Machine 2D graph

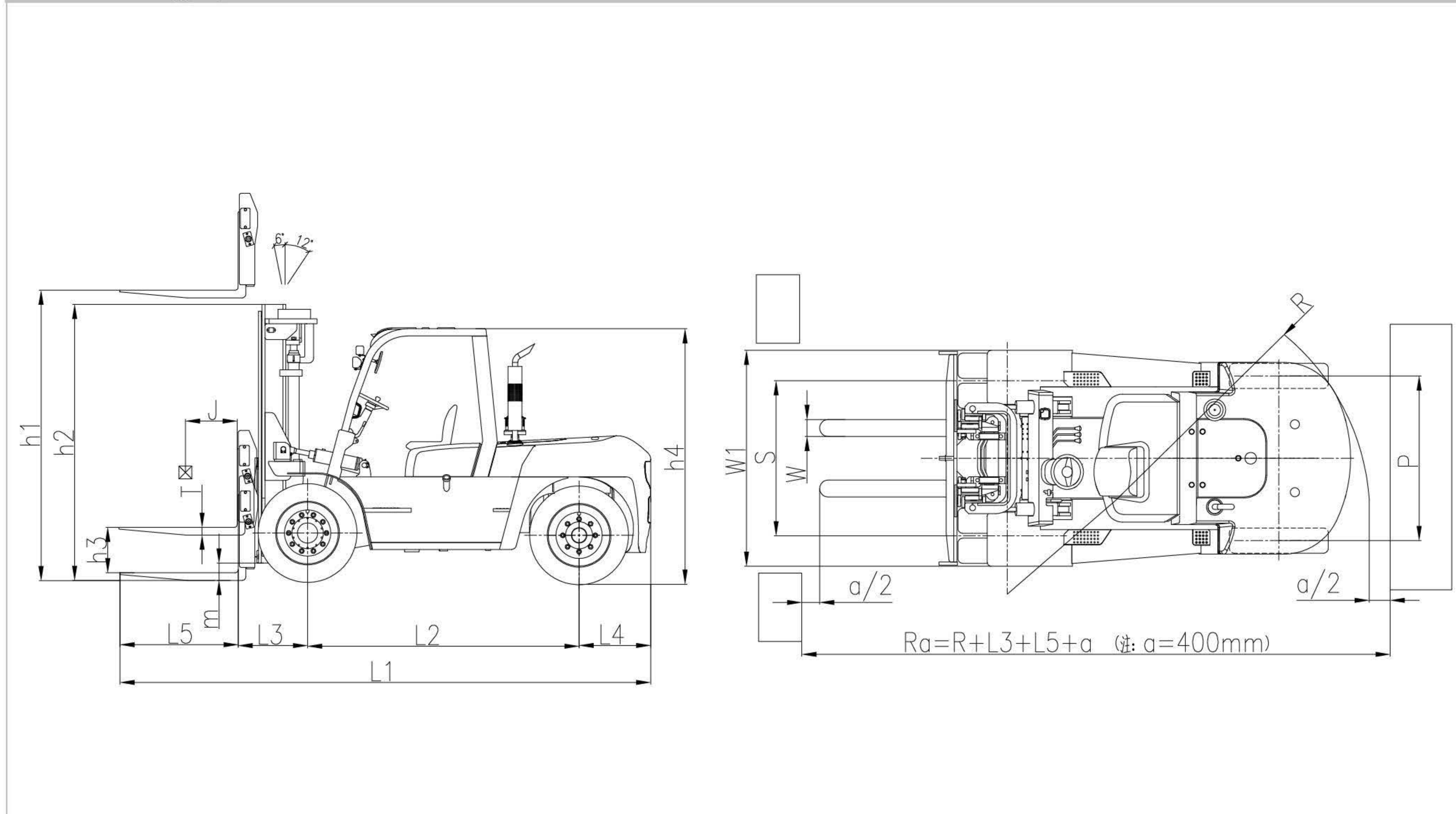

CAPACITY CHART

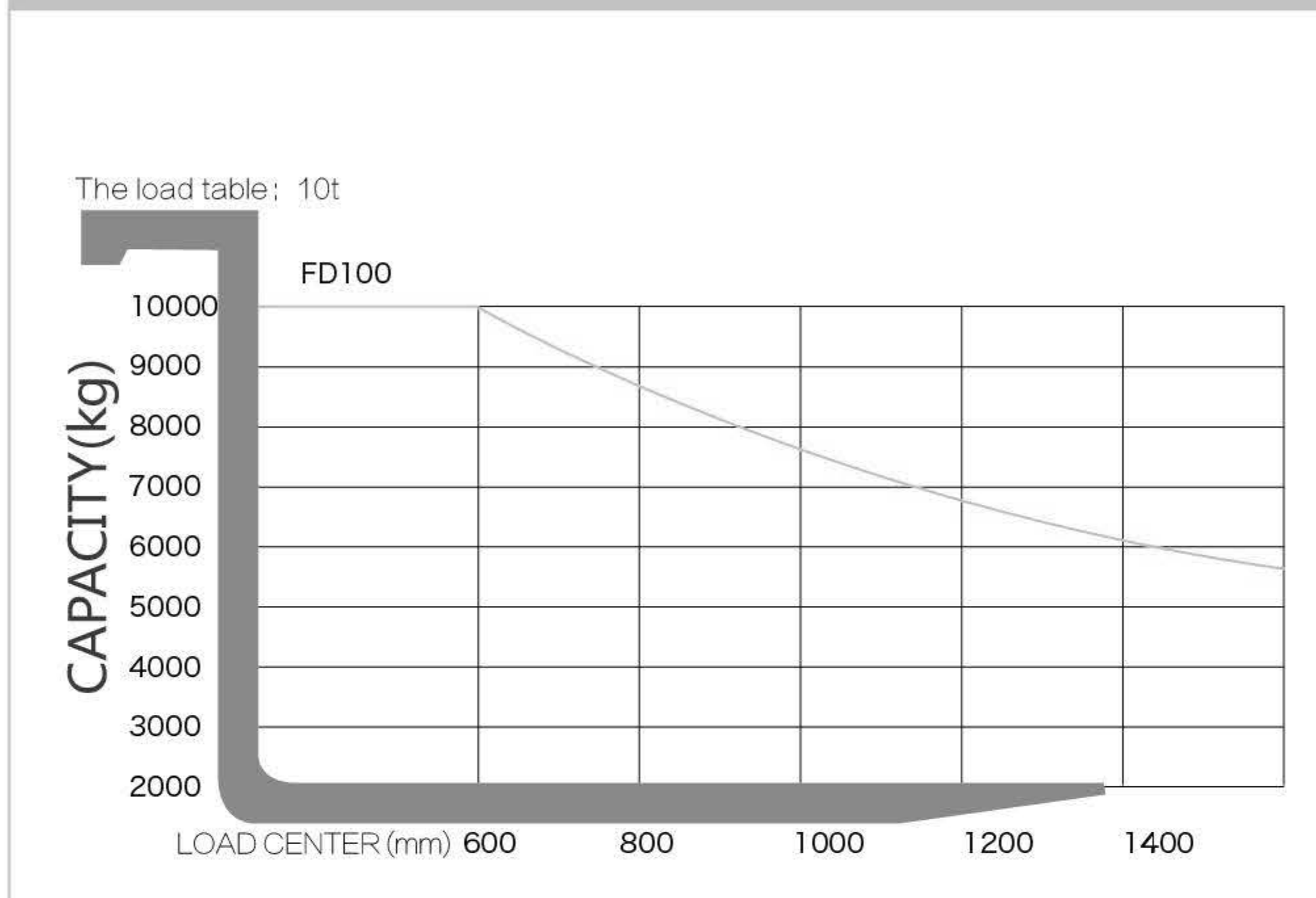

Specification of Optional Engine

| Model | Rated Power/Speed (kW/r.p.m) | Rated torque (N · m/r.p.m) | Displacement (L) |
|--------------------|---------------------------------|-------------------------------|---------------------|
| - | (kW/r.p.m) | (N · m/r.p.m) | (L) |
| XiChai CA6110 | 83/2000 | 450/1450 | 7.127 |
| ISUZU 6BG1QC-02 | 82.4/2000 | 416.8/1500 | 6.494 |
| MITSUBISHI S6K-T | 82.4/2000 | 500/1200 | 6.37 |
| PERKINS 1104D-44TA | 83/2200 | 418/1400 | 4.4 |



FD100 DIESEL FORKLIFT

ZOOMLION ANHUI INDUSTRIAL VEHICLE CO.,LTD

ADD: Building 2, NO.1 Nanwei Road, High-tech Development Zone, Wuhu, Anhui, China
TEL: 0553-3020328 WEB: www.zoomlionfl.com



Scan for details

ZOOMLION



■ DIESEL FORKLIFT FD100

| FEATURES | | FD100 | |
|---|--|--|---|
| Power | — | Diesel | |
| Rated Capacity | kg | 10000 | |
| Center of load | J(mm) | 600 | |
| Lifting height | h1 (mm) | 3000 | |
| Free lifting height | h3(mm) | 220 | |
| Forks L×W×H | L5×W×T(mm) | 1220×175×80 | |
| Tilt Forward/Backward | ° | 6/12 | |
| Min.turning radius | R(mm) | 4280 | |
| Min.Right Angle Aisle Width | Rb(mm) | 3514 | |
| Min.ground clearance(Mast) | Ra(mm) | 6615 | |
| ground clearance(Mast) | m(mm) | 250 | |
| Overhead guard height | h4(mm) | 2600 | |
| Front overhang | L3(mm) | 715 | |
| Rear overhang | L4(mm) | 740 | |
| PERFORMANCE | | | |
| Max.traveling speed(loaded) | km/h | 20 | |
| Max.lifting speed(loaded/empty) | mm/s | 290/350 | |
| Drawbar pull | kN | 57 | |
| Gradeability | % | 20 | |
| SIZE | | | |
| Overall length (with fork) | L1 (mm) | 5475 | |
| Overall width | W1 (mm) | 2230 | |
| Mast lowered height | h2(mm) | 4335 | |
| Mast extended height | mm | 2850 | |
| CHASSIS | | | |
| Tire Front | — | 9.00-20-14PR | |
| Tire Rear | — | 9.00-20-14PR | |
| Wheelbase | L2(mm) | 2800 | |
| Tread width(Front/Rear) | S/P(mm) | 1600/1700 | |
| Curb weight(Non-load) | kg | 12500 | |
| ENGINE | | | |
| Battery(Voltage/Capacity) | V/Ah | (12/90)×2 | |
| Engine(Model) | — | XinChai6110 | |
| Engine(Rated power) | kW/r.p.m | 83/2000 | |
| Engine(Rated torque) | N.m/r.p.m | 450/1450 | |
| Engine(Cylinder amount) | mm | 110×125 | |
| Engine(Bore×Stroke) | — | 6 | |
| Engine(Displacement) | L | 7.127 | |
| Fuel tank | L | 140 | |
| Transmission | — | 2/2 Manual Shift | |
| Working pressure | MPa | 20 | |
| STANDARD CONFIGURATION | | OPTIONS | ATTACHMENT |
| Wideview mast Standard fork Backrest Overhead guard Oil pressure indicator Rearview mirror Timer Fuel Gauge Air intake system Oil scale in torque Double filter | 2 piece multi valve Tornado air filter Speed limit valve Handle Toolbox Rubber pad Traction pin Electric Horn Standard seat Parking brake High exhaust | Adjustable steering wheel Lifting & tilting handle Water temperature gauge Hydraulic oil level gauge Hydraulic oil return filter Rir spring rod for hood Durable pneumatic tire Turning signal Engine flameout device Hydraulic powered steering Double front tire and protector | <input type="checkbox"/> Side shifter <input type="checkbox"/> Fork positioner <input type="checkbox"/> Hinged fork <input type="checkbox"/> Carpet boom <input type="checkbox"/> Extended fork <input type="checkbox"/> Fork cover <input type="checkbox"/> Lifting boom <input type="checkbox"/> Paper roll clamp <input type="checkbox"/> Bale clamp <input type="checkbox"/> Rotator <input type="checkbox"/> Luxury seat <input type="checkbox"/> Cab <input type="checkbox"/> Heater <input type="checkbox"/> Fork cover <input type="checkbox"/> Solid tyre <input type="checkbox"/> Windshield <input type="checkbox"/> Oil-bath double filter(on overheadguard) <input type="checkbox"/> Rotary work alarming light <input type="checkbox"/> Exhaust smoke purification muffler <input type="checkbox"/> Two/three stage full-free mast <input type="checkbox"/> Fire extinguishing muffler <input type="checkbox"/> Barrel clamp <input type="checkbox"/> Tipping fork and bucket |

■ TECHNICAL FEATURES

Safe & Reliable

- Engine is with large torque and capacity, which is powerful and can meet different operation demands;
- Lifting system is equipped with up and down buffer cylinders, which reduce shock and vibration efficiently;
- The forklifts are nice in appearance with streamline design. They work stably with high efficiency and good grade ability and can be operated in bad working conditions;

Comfort & Practical

- Scientific ergonomic design makes operation more portable and comfortable.
- Seat and backrest are adjustable. Steering wheel tilt angle is also adjustable, which leaves more legroom. The portable gearshift is quick to shift and easy to operate;
- Reinforced mast with wide view design improves efficiency and safety, meanwhile enhances anti-force capacity.

| M WIDE VIEW STANDARD MAST | | | | | | |
|---------------------------|----------|---------------------|---------------|----------------------|---------------------|---------------------|
| Lifting Height | Capacity | Maximum lift height | Forks landing | Height with Backrest | Free lifting height | Mast Tilt angle F/R |
| mm | kg | mm | mm | mm | mm | ° |
| 3000 | 10000 | 3000 | 2850 | 4335 | 220 | 6/12 |
| 3500 | 10000 | 3500 | 3100 | 4835 | 220 | 6/12 |
| 4000 | 9500 | 4000 | 3450 | 5335 | 220 | 6/12 |
| 4500 | 9500 | 4500 | 3700 | 5835 | 220 | 6/12 |
| 5000 | 9000 | 5000 | 3950 | 6335 | 220 | 6/6 |
| 5500 | 8000 | 5500 | 4250 | 6835 | 220 | 3/6 |
| 6000 | 7500 | 6000 | 4500 | 7335 | 220 | 3/6 |

The company reserve the right for specification change; Should any revision on specification, a further notice shall prevail.